

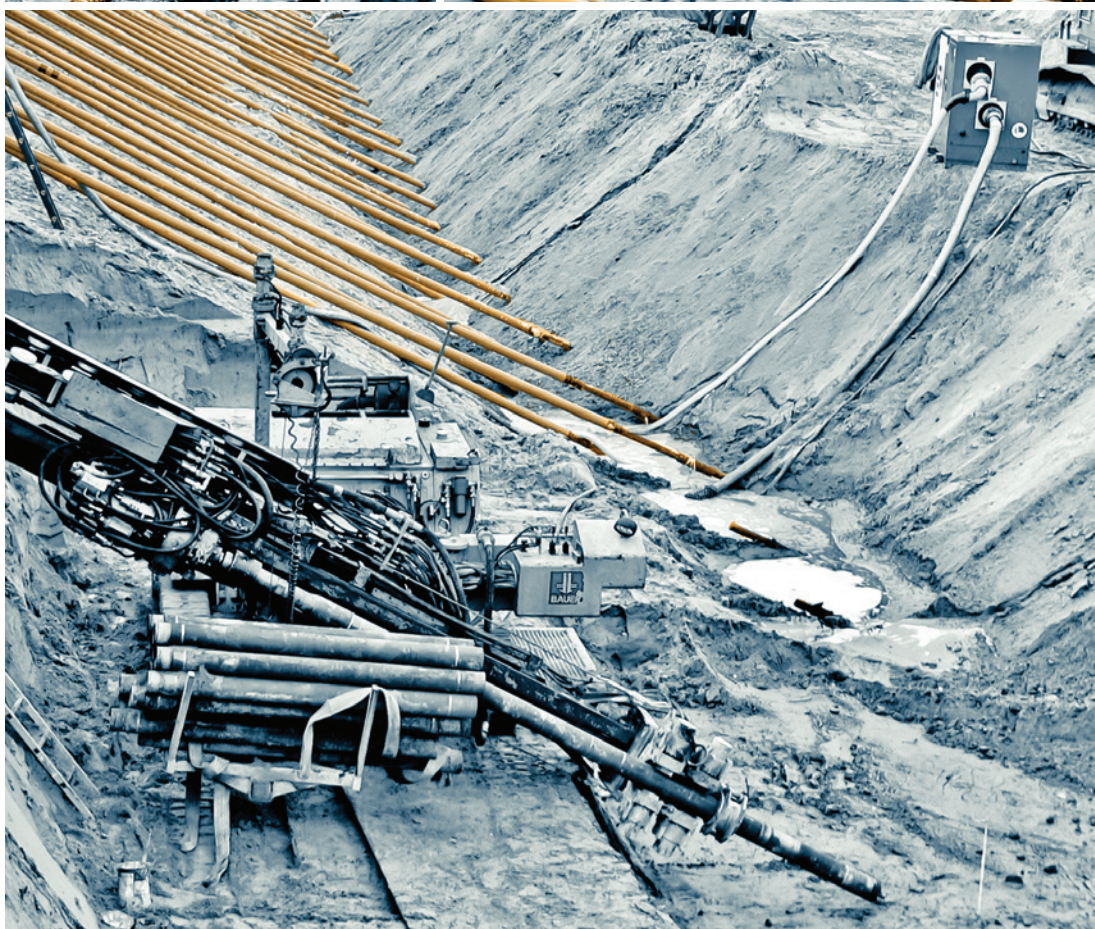

SAH
Stahlwerk Annahütte

SAS Marine Tie

SAS SYSTEMS

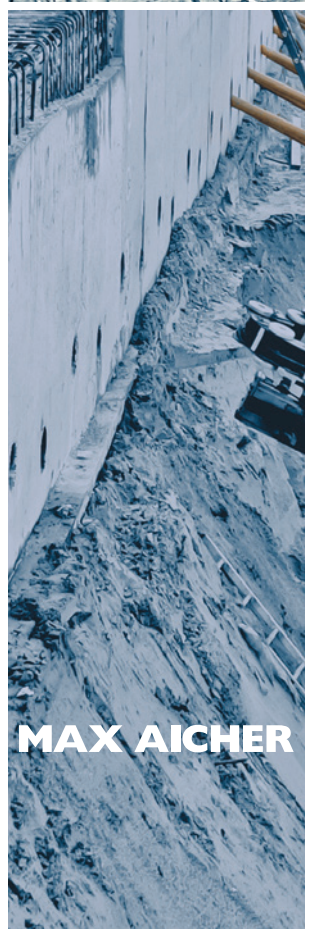

MAX AICHER

Für das Anwendungsgebiet Hafen- und Wasserbau werden SAS Gewindestäbe als Zuganker (horizontale Zugglieder in Verbindung mit einer Ankerwand) oder Bohrverpressanker z.B. für Spundwanddruck Verankerungen eingesetzt. Die mechanisch technologischen Eigenschaften der SAS Gewindestäbe sind unten stehend tabellarisch dargestellt. Das über die gesamte Länge verlaufende Grobgewinde ermöglicht ein universelles Koppeln und Verlängern der eingesetzten Zuganker.

For marine tie application SAS thread bars are used as tie rods (horizontal tie rods in connection with a wall) or ground anchors for example for the sheet pile wall construction. The mechanical technological properties of SAS thread bars are listed in the table. Due to the coarse thread over the total length, cutting and coupling at any length of the installed tie rods is possible

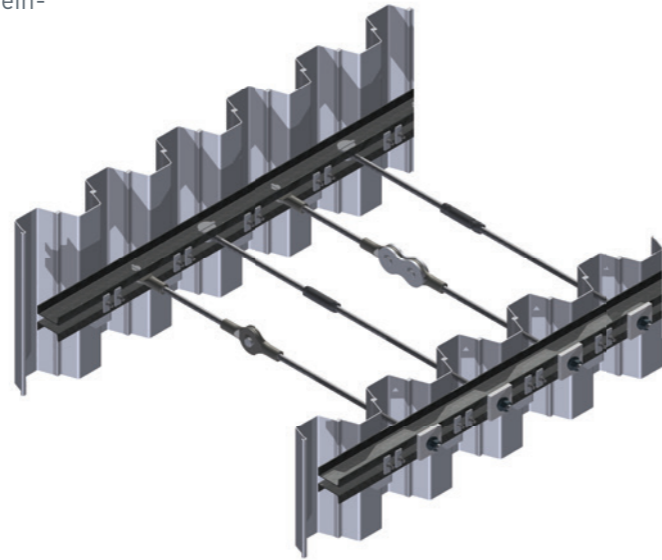

Zugfestigkeit von Zugankern | Tensile resistance of tie rods

Streckgrenze / Zugfestigkeit yield stress / ultimate stress	Nenn- ϕ nom.- ϕ	Strecklast yield load	Bruchlast ultimate load	Zugfestigkeit tensile resistance	Fläche cross section area	Gewicht weight	Dehnung elongation
	[mm]	[kN]	[kN]	¹⁾ min. (F _{tt,Rd} ; F _{tg,Rd})	[mm ²]	[m/to]	[kg/m]
SAS 500 / 550 - grade 75							
	20	160	175	140,0	314	404,9	2,47
	25	245	270	216,0	491	259,7	3,85
	28	310	340	272,0	616	207,0	4,83
	32	405	440	352,0	804	158,5	6,31
	36	510	560	448,0	1020	125,2	7,99
	40	630	690	552,0	1260	101,3	9,87
	43	726	799	639,2	1452	87,7	11,40
	50	980	1080	864,0	1960	64,9	15,40
	75	2209	2430	1944,0	4418	28,8	34,68
SAS 555 / 700 - grade 80							
	57,5	1441	1818	1441,0	2597	49,1	20,38
	63,5	1760	2215	1760,0	3167	40,2	24,86
SAS 670 / 800 - grade 97							
	18	170	204	163,2	254	500,0	2,00
	22	255	304	243,2	380	335,6	2,98
	25	329	393	314,4	491	259,7	3,85
	28	413	493	394,4	616	207,0	4,83
	30	474	565	452,0	707	180,2	5,55
	35	645	770	616,0	962	132,5	7,55
	43	973	1162	929,6	1452	87,7	11,40
	50	1315	1570	1256,0	1963	64,9	15,40
	57,5	1740	2077	1661,6	2597	49,1	20,38
	63,5	2122	2534	2027,2	3167	40,2	24,86
	75	2960	3535	2828,0	4418	28,8	34,68

¹⁾entsprechend DIN EN 1993-5 (EC 3) - EAU 2014 E 20 - k_t = 1,0
acc. DIN EN 1993-5 (EC 3) - EAU 2014 E 20 - k_t = 1,0

Entsprechend der DIN EN 1993-5 (EC3) und der EAU 2014 E20 („Empfehlungen des Arbeitsausschusses „Ufereinfassungen, Häfen und Wasserstraßen“) berechnet sich die Zugfestigkeit des Zugankers (F_t, R_d) aus dem Minimum, aus der Zugfestigkeit aus dem Gewinde (F_{tt}, R_d) und der Zugfestigkeit aus dem Schaft (F_{tg}, R_d).

In accordance with der DIN EN 1993-5 (EC3) an the EAU 2014 E20 (“Recommendations of the Committee for „Waterfront Structures, Harbours and Waterways“) the tensile resistance of a tie rod (F_t, R_d) is calculated as the minimum of the tensile resistance of the thread part (F_{tt}, R_d) and the tensile resistance of the shaft (F_{tg}, R_d).

$$F_{t, Rd} = \text{minimum of : } \begin{cases} F_{tg, Rd} = A_g \times f_y / \gamma_{m0} \\ F_{tt, Rd} = k_t \times f_{ua} \times A_s / \gamma_{m2} \end{cases}$$

- A_g = Bruttoquerschnittsfläche des Ankers / gross cross sectional area of anchor
- A_s = Zugspannungsbereich der Gewinde / tensile stress area of thread
- f_y = Streckgrenze / yield strength
- f_{ua} = Zugfestigkeit / ultimate strength
- k_t = Abminderungsfaktor für Kombination Biege Zug im Gewindebereich (0,6 wo mit Biegung im Anschlussbereich gerechnet werden muss und 0,9 wo bauliche Maßnahmen Biegung im Gewindebereich eliminieren) / a reduction factor allowing for combined bending and tension in the thread (typically 0,6 where bending at the connection must be considered and 0,9 where structural detailing eliminates bending at the connections)

γ_{m0} + γ_{m2} = Sicherheitsfaktoren entspr. DIN EN 1993-5 (1,0 + 1,25) / Safety factors acc. DIN EN 1993-5 (1,0 + 1,25)

Auf Grund der Gewindeherstellung empfiehlt SAH die Verwendung des k_t- Faktors (Kerbfaktor) = 1,0 für alle Ansätze.

Due to the threading SAH recommends using the k_t- factor (notch factor) = 1.0 for all approaches.

Der Einfluss durch Biege Zug auf den SAH Gewindestab unterscheidet sich nicht von dem Einfluss durch Biege Zug auf einen Rundanker. Der k_t-Faktor kann daher vernachlässigt werden.

The influence by bending-tension on the SAH threaded tie rod is no different from the influence by bending-tension on a smooth rod. The k_t-factor can therefore be neglected.

Im Gegensatz zu den üblichen gerollten oder geschnittenen Gewinden haben die SAS Zuganker ein warmgewalztes Gewinde!

Contrary to the usual rolled or cut threads, the SAS tie rods have a hot rolled thread!

Walz- oder Herstellfasern | rolling oder fabrication fibers



Warmgewalztes Gewinde (SAH)
Hot rolled thread

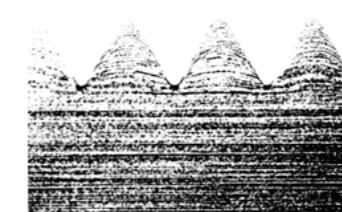

Gerolltes Gewinde
Rolled thread

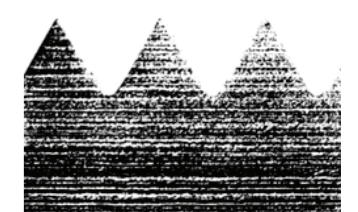

Geschnittenes Gewinde
Cutted thread

Ø [mm]	SW x L x d [mm]	[kg]	SW x L x d [mm]	[kg]
Ankermutter anchor nut				
	T 2002 - Ø		TR 2002 - Ø	
35	-	-	65 x 70	1,38
40	65 x 70	1,19	-	-
43	70 x 75	1,51	79 x 90	2,62
50	79 x 90	2,17	79 x 100	2,53
57,5	90 x 110 x 102	4,13	90 x 120 x 102	4,53
63,5	100 x 115 x 108	4,72	100 x 145 x 114	6,97
75	100 x 100 x 108	2,99	100 x 130 x 108	3,86

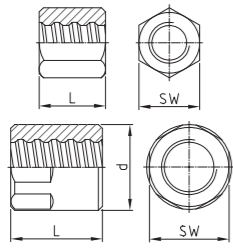

Ø [mm]	SW x L x d [mm]	[kg]	SW x L x d [mm]	[kg]
Kugelbundmutter 55° domed nut 55°				
	T 2044 - Ø		TR 2001 - Ø	
35	-	-	60 x 70 x 83	1,40
40	60 x 70 x 88	1,50	-	-
43	70 x 80 x 100	2,12	70 x 85 x 102	2,22
50	80 x 85 x 107	2,57	80 x 100 x 116	3,44
57,5	90 x 100 x 120	3,79	90 x 115 x 137	5,69
63,5	100 x 115 x 144	5,51	100 x 125 x 151	7,52
75	100 x 120 x 160	6,62	120 x 150 x 178	12,94

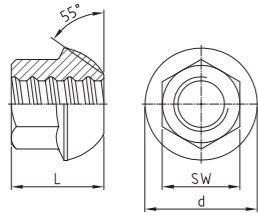

Ø [mm]	SW x L x d [mm]	[kg]	SW x L x d [mm]	[kg]
Ankerstück anchor piece				
	T 2073 - Ø		TR 2073 - Ø	
35	-	-	60 x 70 x 105	1,66
40	65 x 70 x 120	2,10	-	-
43	70 x 80 x 130	2,43	70 x 85 x 130	2,74
50	80 x 85 x 150	3,88	80 x 100 x 150	3,63
57,5	90 x 100 x 175	6,09	90 x 115 x 175	6,96
63,5	100 x 115 x 190	7,38	100 x 125 x 190	8,78
75	-	-	120 x 150 x 230	15,03

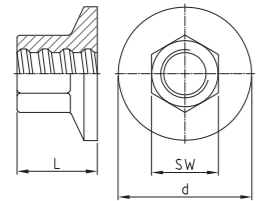

Ø [mm]	SW x L x d [mm]	[kg]	SW x L x d [mm]	[kg]
Kontermutter lang lock nut long				
	T 2003 - Ø		TR 2003 - Ø	
35	-	-	55 x 65	0,78
40	60 x 65	0,85	-	-
43	70 x 65	1,31	70 x 80	1,60
50	79 x 80	2,10	79 x 90	2,27
57,5	90 x 80 x 102	2,87	90 x 100 x 102	3,71
63,5	90 x 115 x 102	3,74	100 x 115 x 114	5,45
75	100 x 80 x 108	2,37	100 x 120 x 108	4,20

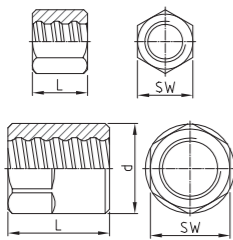

Ø [mm]	SW x L x d [mm]	[kg]	SW x L x d [mm]	[kg]
Kontermutter, kurz lock nut, short				
	T 2040 - Ø		TR 2040 - Ø	
35	-	-	55 x 40	0,47
40	60 x 35	0,45	-	-
43	70 x 40	0,80	70 x 50	1,00
50	79 x 50	1,30	79 x 50	1,26
57,5	90 x 60 x 102	2,08	90 x 60 x 102	2,04
63,5	90 x 75 x 102	2,28	100 x 70 x 114	3,07
75	100 x 80 x 108	2,37	100 x 80 x 108	2,70

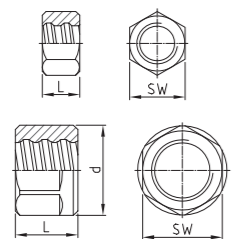

Ø [mm]	SW x L x d [mm]	[kg]	SW x L x d [mm]	[kg]
Ankerplatte, gerade anchor plate, flat				
	T 2139 - Ø		TR 2139 - Ø	
35	-	-	150 x 40 x 42	6,63
40	150 x 30 x 47	4,89	-	-
43	160 x 40 x 50	7,42	185 x 55 x 50	13,93
50	190 x 45 x 58	11,82	215 x 60 x 60	20,44
57,5	220 x 50 x 67	17,61	245 x 65 x 67	28,83
63,5	245 x 50 x 70	22,05	270 x 70 x 74	37,70
75	275 x 65 x 88	35,48	325 x 70 x 86	54,85

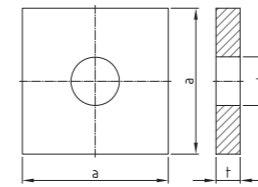

Ø [mm]	a x t x d ₁ x d ₂ [mm]	[kg]	a x t x d ₁ x d ₂ [mm]	[kg]
Ankerplatte, Konus 55° anchor plate, cone 55°				
	T 2011 - Ø		TR 2011 - Ø	
35	-	-	170 x 40 x 47 x 73	8,36
40	150 x 30 x 65 x 76	4,48	-	-
43	160 x 40 x 75 x 93	6,54	210 x 50 x 58 x 90	15,96
50	190 x 45 x 83 x 96	10,78	240 x 55 x 70 x 110	22,59
57,5	220 x 50 x 92 x 110	16,25	275 x 60 x 75 x 119	32,77
63,5	245 x 50 x 104 x 121	20,09	300 x 65 x 82 x 131	42,19
75	275 x 65 x 118 x 145	32,60	325 x 70 x 100 x 159	51,89

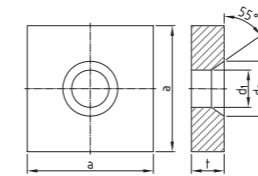

Ø [mm]	a x t x d ₁ x d ₂ x L [mm]	[kg]	a x t x d ₁ x d ₂ x L [mm]	[kg]
Ankerplatte, Konus 55° mit Auflager anchor plate, cone 55° with support				
	T 2011 ST - Ø		TR 2011 ST - Ø	
35	-	-	170 x 40 x 47 x 73	8,63
40	150 x 30 x 65 x 76 x 40	4,72	-	-
43	160 x 40 x 75 x 93 x 50	6,79	210 x 50 x 58 x 90	16,29
50	190 x 45 x 83 x 96 x 55	11,08	240 x 55 x 70 x 110	22,97
57,5	220 x 50 x 92 x 110 x 60	16,60	275 x 60 x 75 x 119	33,20
63,5	245 x 50 x 104 x 121 x 60	20,48	300 x 65 x 82 x 131	42,66
75	275 x 65 x 118 x 145 x 75	33,03	325 x 70 x 100 x 159	52,40

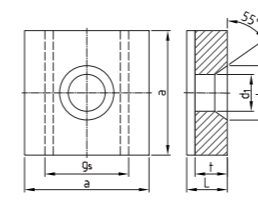

Ø [mm]	d x L [mm]	[kg]	d x L [mm]	[kg]
Muffe standard coupler standard				
	T 3003 - Ø		TR 3003 - Ø	
35	-	-	65 x 180	3,16
40	65 x 160	2,34	-	-
43	80 x 170	4,49	80 x 200	5,42
50	80 x 200	4,49	90 x 210	6,92
57,5	102 x 230	9,54	102 x 250	10,37
63,5	102 x 260	9,45	114 x 300	15,85
75	108 x 240	8,01	108 x 260	8,98

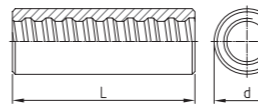

Ø [mm]	d x L [mm]	[kg]	d x L [mm]	[kg]
Muffe mit Drehsicherung coupler with set screws				
	T 3020 - Ø		TR 3020 - Ø	
35	-	-	65 x 180	3,13
40	65 x 160	2,35	-	-
43	80 x 170	4,41	80 x 200	5,40
50	80 x 200	4,50	90 x 210	6,82
57,5	102 x 230	9,45	102 x 250	10,00
63,5	102 x 260	9,41	114 x 300	14,70
75	108 x 240	8,02	108 x 260	8,90

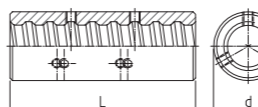

g₃ nach Kundenwunsch | g₃ on customer request

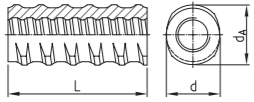
	Ø [mm]	d x d _A x L [mm]	[kg]	d x d _A x L [mm]	[kg]
Gewindemuffe thread coupler		T 3087 - Ø		TR 3087 - Ø	
	35	-	-	65 x 72 x 180	3,22
	40	65 x 72 x 160	2,52	-	-
	43	75 x 82 x 170	3,79	75 x 82 x 200	4,77
	50	-	-	-	-
	57,5	-	-	-	-
	63,5	-	-	-	-
	75	-	-	-	-

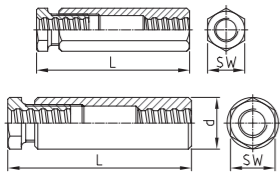
	Ø [mm]	SW x L x d [mm]	[kg]	SW x L x d [mm]	[kg]
Spannschloss turnbuckle		T 2044 - Ø		TR 2001 - Ø	
	35	-	-	79 x 275	8,27
	40	79 x 270	7,31	-	-
	43	90 x 290 x 105	13,46	90 x 330 x 105	15,14
	50	100 x 310 x 115	16,89	100 x 350 x 115	19,04
	57,5	100 x 340 x 125	20,37	100 x 405 x 125	24,46
	63,5	100 x 395 x 130	24,11	100 x 425 x 120	21,56
	75	110 x 370 x 130	19,67	110 x 460 x 130	25,20

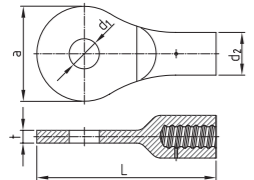
	Ø [mm]	a x L x t x d ₁ x d ₂ [mm]	[kg]	a x L x t x d ₁ x d ₂ [mm]	[kg]
Augenstück eye piece		T 2080 - Ø EP		TR 2080 - Ø EP	
	35	auf Anfrage on request	-	167 x 315 x 23 x 53 x 75	7,18
	40		-	-	
	43		197 x 384 x 25 x 63 x 92	12,54	
	50		221 x 406 x 31 x 75 x 92	17,99	
	57,5		248 x 469 x 38 x 88 x 96	21,57	
	63,5		298 x 558 x 38 x 98 x 114	33,45	
	75		328 x 627 x 50 x 108 x 116	46,13	

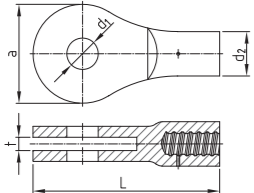
	Ø [mm]	a x L x t x d ₁ x d ₂ [mm]	[kg]	a x L x t x d ₁ x d ₂ [mm]	[kg]
Gabelstück fork piece		T 2090 - Ø EP		TR 2090 - Ø EP	
	35	auf Anfrage on request	-	167 x 315 x 27 x 53 x 75	7,40
	40		-	-	
	43		197 x 384 x 29 x 63 x 92	12,80	
	50		221 x 406 x 35 x 75 x 94	14,75	
	57,5		248 x 454 x 42 x 88 x 96	20,40	
	63,5		298 x 553 x 42 x 98 x 114	34,50	
	75		-	-	

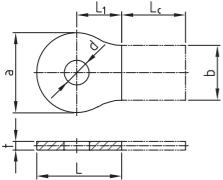
	Ø [mm]	a x L x L ₁ x t x d x b [mm]	[kg]	a x L x L ₁ x t x d x b [mm]	[kg]
Verbindungslasche Augenstück strap connection eye piece		T 3081 - Ø		TR 3081 - Ø EP	
	35	auf Anfrage on request	-	167 x 177 x 94 x 18 x 53 x 114 x Lc	3,10 + Lc
	40		-	-	
	43		197 x 207 x 109 x 20 x 63 x 134 x Lc	4,72 + Lc	
	50		-	-	
	57,5		248 x 263 x 139 x 30 x 88 x 160 x Lc	10,95 + Lc	
	63,5		298 x 313 x 164 x 30 x 98 x 200 x Lc	17,95 + Lc	
	75		328 x 346 x 182 x 35 x 108 x 220 x Lc	22,75 + Lc	

Lc nach Kundenwunsch | Lc on customer request

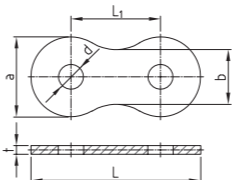
	Ø [mm]	a x L x t x d x L ₁ x b [mm]	[kg]	a x L x t x d x L ₁ x b [mm]	[kg]
Verbindungslasche Augenstück strap connection eye piece		T 3080 - Ø		TR 3080 - Ø	
	35	auf Anfrage on request	-	167 x 354 x 18 x 53 x 187 x 114	7,00
	40		-	-	
	43		197 x 414 x 20 x 63 x 217 x 134	9,60	
	50		-	-	
	57,5		248 x 526 x 30 x 88 x 278 x 160	22,00	
	63,5		298 x 626 x 30 x 98 x 328 x 200	31,80	
	75		328 x 691 x 35 x 108 x 363 x 220	45,80	

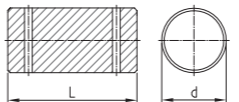
	Ø [mm]	d x L [mm]	[kg]	d x L [mm]	[kg]
Bolzen Augenstück bolt eye piece		T 2081 - Ø		TR 2081 - Ø	
	35	auf Anfrage on request	-	50 x 100	1,52
	40		-	-	
	43		60 x 110	2,40	
	50		72 x 105	3,31	
	57,5		85 x 145	6,45	
	63,5		95 x 145	8,02	
	75		105 x 165	11,21	

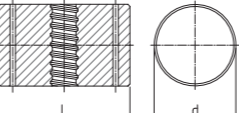
	Ø [mm]	d x L [mm]	[kg]	d x L [mm]	[kg]
Gelenkmutter joint nut		T 2020 - Ø		TR 2020 - Ø	
	35	auf Anfrage on request	-	120 x 193	16,00
	40		-	-	
	43		140 x 212	23,80	
	50		-	-	
	57,5		150 x 222	27,00	
	63,5		190 x 265	53,40	
	75		190 x 279	55,00	

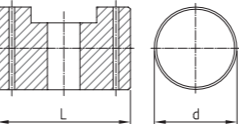
	Ø [mm]	d x L [mm]	[kg]	d x L [mm]	[kg]
Gelenkbolzen joint bolt		T 2021 - Ø		TR 2021 - Ø	
	35	auf Anfrage on request	-	120 x 193	14,60
	40		-	-	
	43		140 x 212	21,20	
	50		-	-	
	57,5		150 x 222	24,60	
	63,5		190 x 265	51,06	
	75		190 x 279	52,00	

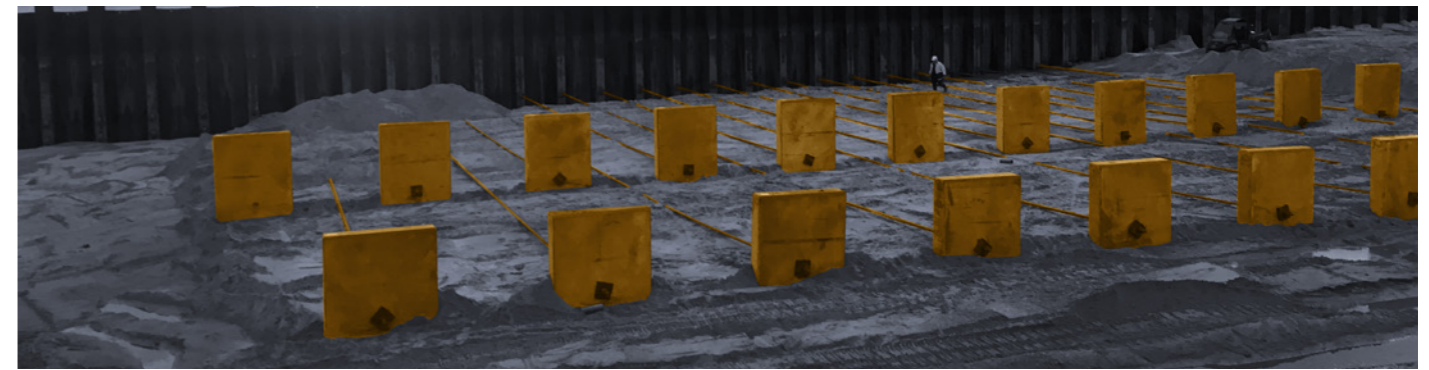

Verbindung mit der Spundwand

Die Lasten werden über die Spundwand auf die Zugstäbe durch die vor der Wand angeordnete Gurtung übertragen. Um Biegungen im Anschlussbereich des Zugstabes zur Gurtung zu minimieren, werden gelenkige Verbindungen empfohlen.

Für verschiedene Gurtspreizungen g_s sind in unten stehender Tabelle Plattendimensionen angegeben. Die Werte für die Plattenbreite h sind Mindestwerte $\min h$. Die Auflagerlänge der Platten auf den U-Profilen beträgt ≥ 30 mm. Für Auflagerlängen ≥ 30 mm sind die Platten gesondert statisch nachzuweisen. Die dargestellten Plattendimensionen gelten für geradeliegende Anker. Gurtspreizungen g_s

Connections to sheet piles

Forces are transferred from the sheet pile wall to the tie rod through walers which are installed at the wall. To minimize bending at the connection from the tie rod to the waler, articulation connections are recommended.

For different waling bracings g_s the below-mentioned table shows dimensions for the plates. The dimensions of the plate width h are minimum values $\min h$. The bearing length of the plates on the U-profiles is ≥ 30 mm. For bearing length ≤ 30 mm a statical verification has to be done separately. The dimensions of the plates are valid for straight-lined anchors. waling bracings g_s

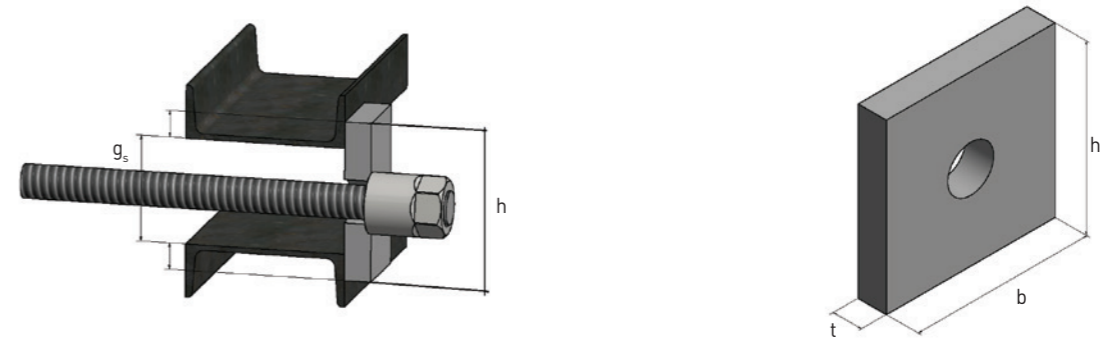
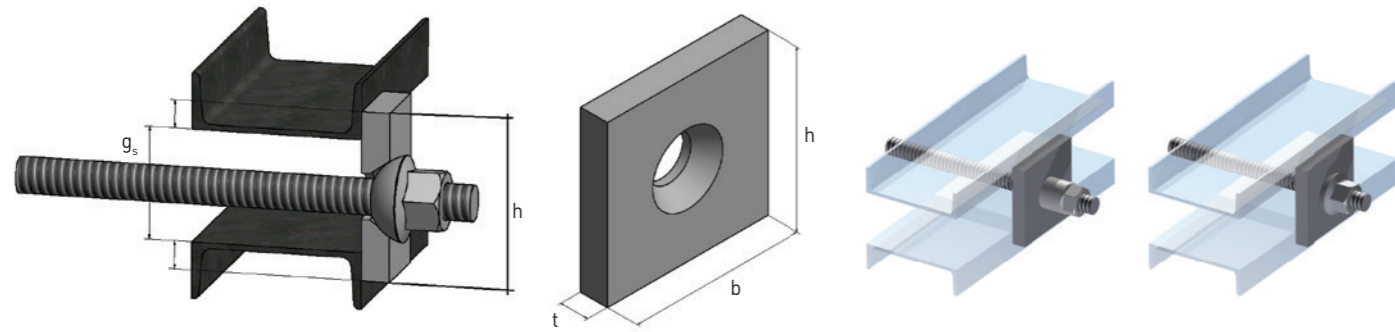

Ankerplatte Konus 55° | anchor plate cone 55°

g_s [mm]	80						100						120						140							
	\emptyset	h	b	t	d_L	d_k	[kg]	h	b	t	d_L	d_k	[kg]	h	b	t	d_L	d_k	[kg]	h	b	t	d_L	d_k	[kg]	
40	140	150	30	65	76	4,13	160	150	35	65	76	5,64	180	180	35	65	76	7,95	-	-	-	-	-	-	-	-
43	140	160	35	75	93	4,82	160	160	40	75	93	6,53	180	190	40	75	93	9,23	-	-	-	-	-	-	-	-
50	-	-	-	-	-	-	160	180	45	83	96	8,20	180	200	50	83	96	11,94	-	-	-	-	-	-	-	-
57,5	-	-	-	-	-	-	160	190	55	92	110	10,11	180	200	60	92	110	13,68	200	200	60	92	110	15,56	-	-
63,5	-	-	-	-	-	-	-	-	-	-	-	-	180	220	65	104	121	15,73	200	200	65	104	121	15,94	-	-
75	-	-	-	-	-	-	-	-	-	-	-	-	-	-	-	-	-	-	200	200	70	118	145	15,55	-	-
35	140	150	30	47	73	4,36	160	150	35	47	73	5,94	180	180	35	47	73	8,25	-	-	-	-	-	-	-	-
43	140	180	40	58	90	6,75	160	180	45	58	90	8,91	180	180	45	58	90	10,18	-	-	-	-	-	-	-	-
50	140	190	50	70	110	8,30	160	190	55	70	110	10,83	180	200	55	70	110	13,25	-	-	-	-	-	-	-	-
57,5	140	200	55	75	119	9,35	160	190	65	75	119	12,43	180	200	65	75	119	15,29	200	200	65	75	119	17,33	-	-
63,5	-	-	-	-	-	-	160	200	70	82	131	13,56	180	200	70	82	131	15,75	200	200	75	82	131	19,32	-	-
75	-	-	-	-	-	-	-	-	-	-	-	-	180	230	85	100	159	20,40	200	240	80	100	159	23,23	-	-

Ankerplatte Konus 55° | anchor plate cone 55°

g_s [mm]	80						100						120						140							
	\emptyset	h	b	t	d_L	[kg]	h	b	t	d_L	[kg]	h	b	t	d_L	[kg]	h	b	t	d_L	[kg]	h	b	t	d_L	[kg]
40	140	150	35	47	5,30	160	170	40	47	8,00	180	200	40	47	10,76	-	-	-	-	-	-	-	-	-	-	-
43	140	150	40	50	5,98	160	170	40	50	7,93	180	200	45	50	12,03	-	-	-	-	-	-	-	-	-	-	-
50	140	160	45	58	6,98	160	180	45	58	9,25	180	200	50	58	13,10	-	-	-	-	-	-	-	-	-	-	-
57,5	140	190	55	67	9,97	160	200	55	67	12,30	180	200	60	67	15,30	200	220	65	67	20,66	-	-	-	-	-	-
63,5	140	200	60	70	11,38	160	200	65	70	14,37	180	220	65	70	18,25	200	220	70	70	22,07	-	-	-	-	-	-
75	-	-	-	-	-	-	180	200	70	88	16,44	180	240	70	88	20,40	200	220	75	88	22,33	-	-	-	-	-
35	140	140	40	42	5,72	160	170	40	42	8,11	180	180	45	42	10,96	-	-	-	-	-	-	-	-	-	-	-
43	140	160	45	50	7,22	160	170	50	50	9,91	180	200	50	50	13,36	-	-	-	-	-	-	-	-	-	-	-
50	140	180	50	60	8,79	160	180	55	60	11,22	180	210	55	60	15,10	-	-	-	-	-	-	-	-	-	-	-
57,5	140	200	60	67	11,53	160	200	60	67	13,42	180	220	65	67	18,41	200	220	70	67	22,25	-	-	-	-	-	-
63,5	140	200	70	74	13,03	160	200	70	74	15,23	180	220	70	74	19,40	200	240	75	74	25,73	-	-	-	-	-	-
75	-	-	-	-	-	-	160	240	80	86	20,47	180	220	85	86	22,25	200	260	85	86	30,83	-	-	-	-	-

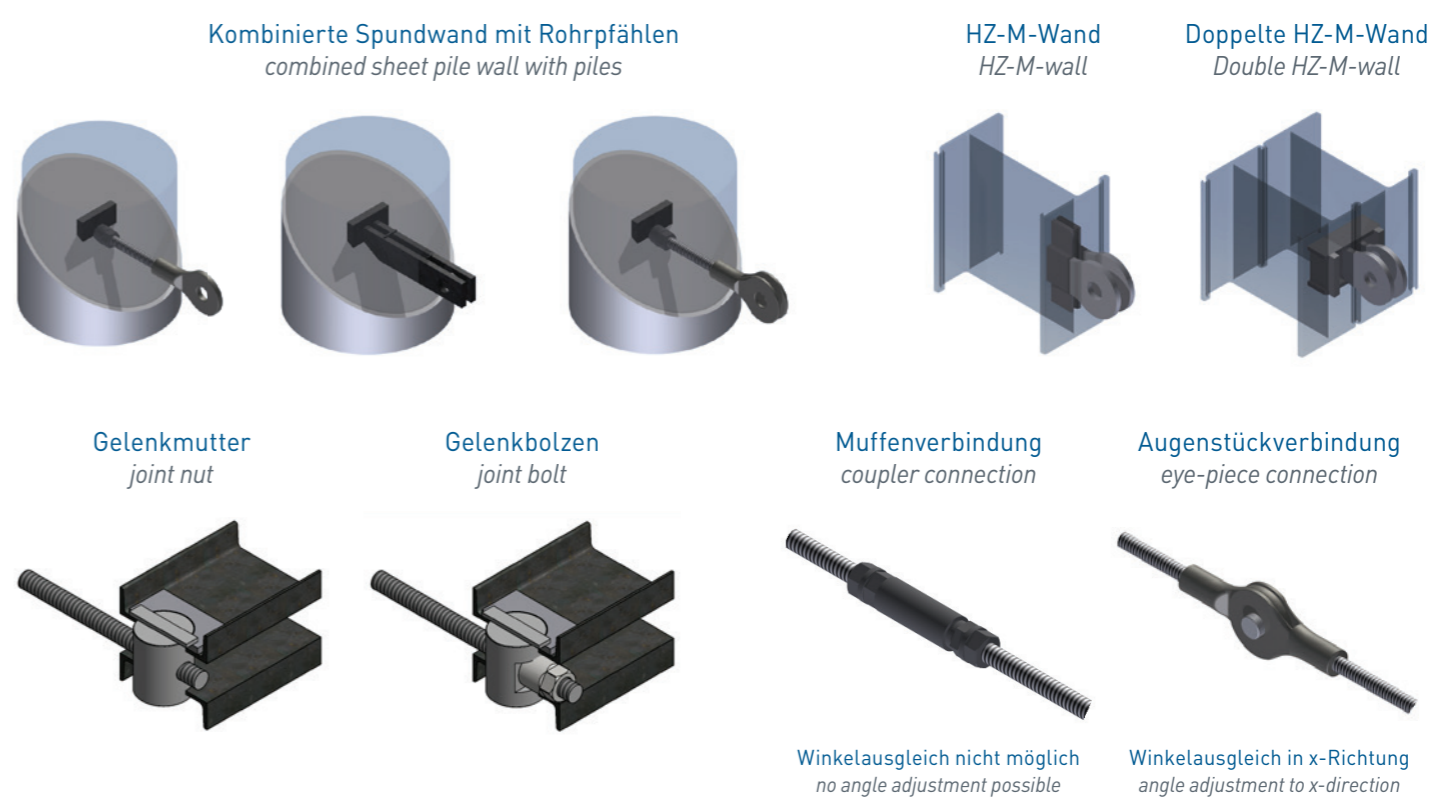

Winkelausgleich nicht möglich
no angle adjustment possible

Winkelausgleich in x-Richtung
angle adjustment to x-direction

SAS Gewindestäbe und Zubehör können durch verschiedene Beschichtungssysteme gegen Korrosion geschützt werden. Je nach Anwendung variiert die Anforderung an das Beschichtungssystem. Die gängigsten Beschichtungssysteme für SAS Gewindestäbe und Zubehör sind nachfolgend beschrieben.

To protect SAS thread bars and accessories against corrosion different kinds of coating systems are available. The types of coating system can vary in accordance to the application. Some of the coating systems for SAS thread bars and accessories are described in the following chapter.

Abrostraten nicht geschützter Stäbe | Sacrificial corrosion of unprotected thread bars



Stahlbauteile können überdimensioniert eingebaut werden, um den Querschnittsverlust beim „Abrosten“ zu kompensieren. Abhängig vom Baugrund können entspr. DIN EN 1993-5:2010 Tab. 4-2 folgende Werte angesetzt werden:

Steel elements may be oversized to allow for loss of cross sectional area due to corrosion. Depending on the ground conditions, [DIN EN 1993-5:2010 Tab. 4-2] is suggesting the following loss of thickness of thread bars in the ground may be considered:

Lebensdauer / Lifetime	Korrosionsschutzsysteme / Corrosion protection systems	Bodenaggressivität / Soil Aggressiveness in accordance with 1)			
		niedrig / low	mittel / medium	Hoch / high	
Temporär / temporary < 2 Jahre / years	Abrostraten nicht geschützter Stäbe	Sacrificial corrosion of unprotected bars	ü	ü	ü
	Denso Flex - Bandumwicklung	Denso Flex - wrapping	---	---	---
	Feuerverzinkung	Hot-dip galvanizing	---	ü	ü
	Schrumpfschlauch	Heat shrink sleeves	---	---	---
	Doppelter Korrosionsschutz (DCP)	Double corrosion protection (DCP)	---	---	---
Semi-permanent / semi-permanent 2 - 7 Jahre / years	Abrostraten nicht geschützter Stäbe	Sacrificial corrosion of unprotected bars	ü	ü	ü
	Denso Flex - Bandumwicklung	Denso Flex - wrapping	---	---	---
	Feuerverzinkung	Hot-dip galvanizing	ü	ü	ü
	Schrumpfschlauch	Heat shrink sleeves	---	---	---
Permanent	Doppelter Korrosionsschutz (DCP)	Double corrosion protection (DCP)	ü	ü	ü
	Abrostraten nicht geschützter Stäbe	Sacrificial corrosion of unprotected bars	ü	ü	---
> 7 Jahre / years	Denso Flex - Bandumwicklung	Denso Flex - wrapping	ü	---	---
	Feuerverzinkung	Hot-dip galvanizing	ü	ü	---
	Schrumpfschlauch	Heat shrink sleeves	---	ü	ü
	Doppelter Korrosionsschutz (DCP)	Double corrosion protection (DCP)	ü	ü	ü

¹⁾in Anlehnung an die DIN EN 12501 | in accordance with DIN EN 12501

Geforderte planmäßige Nutzungsdauer [Jahre] Required scheduled useful life [years]	25	50
	Dickenverlust loss of steel thickness [mm]	
Allgemeines Süßwasser (Fluss, Schiffskanal, ...) im Bereich hohen Angriffes (Wasserspiegel)	0,55	0,90
Sehr verunreinigtes Süßwasser (Abwasser, Industrieabwasser, ...) in der Zone hohen Angriffes (Wasser-spiegel)	1,30	2,30
Seewasser in gemäßigttem Klima im Bereich hohen Angriffes (Niedrig-wasser und Spritzzone)	1,90	3,75
Seewasser in gemäßigttem Klima im Bereich, der ständig unter Wasser ist, oder in der Wasser-wechselzone	0,90	1,75

Die o.g. Werte gelten nur als Hinweis und müssen entspr. den örtlichen Gegebenheiten angepasst werden.

The values above are for guidance only. Local conditions should be considered and suitable values taken into account.

Denso Flex - Bandumwicklung | Denso Flex - wrapping



Denso Flex ist ein kaltverarbeitbares Petrolatum-band, d.h. ein Vlies das mit einer beidseitig korrosionsschützenden Masse beschichtet ist. SAS Zuganker können mit diesem Petrolatumband umwickelt werden. Achtung: Mit Denso Flex umwickelte Gewindestäbe sind nicht schraubbar.

Denso Flex is a cold applied petrolatum tape, e.g. a double-sided coated fleece with a special corrosion material. SAS tie rods can be wrapped with this petrolatum tape. Warning: With Denso Flex wrapped thread bars are not threadable.



Feuerverzinkung | Hot-dip galvanizing



Gewindestähle der Güten SAS 670/800 und SAS 500/550 bzw. 555/700 können feuerverzinkt werden. Eine maximale Schichtdicke von ca. 200 µm sollte auf Grund der Schraubbarkeit mit dem entsprechenden Zubehör nicht überschritten werden. Nach DIN EN ISO 1461 beträgt die örtliche Schichtdicke (Mindestwert) 70 µm und die durchschnittliche Schichtdicke (Mindestwert) 85 µm. Neben der DIN EN ISO 1461 erfolgt das Feuerverzinken der SAS Gewindestäbe nach BS 729 (EN ISO 1461) und ASTM A 123, 153, 767.

Thread bars of the steel grade SAS 670/800 and SAS 500/550 resp. 555/700 can be hot-dip galvanized. A maximum coating thickness of approx. 200 µm should not be exceeded because of the tradability with the accessories. Acc. DIN EN ISO 1461 the local coating thickness (minimum) is 70 µm and the average coating thickness (minimum) is 85 µm. In addition to the standard DIN EN ISO 1461 the hot-dip galvanizing of the SAS thread bars is in accordance with BS 729 (EN ISO 1461) and ASTM A 123, 153, 767.

Schrumpfschlauch | Heat shrink sleeves

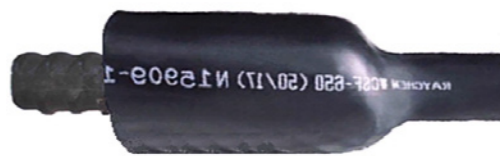

Schrumpfschläuche in Kombination mit einem PE-Rohr als Schutz vor mechanischen Beanspruchungen sind ein dauerhaftes Korrosionsschutzsystem für SAS Zuganker. Schrumpfschläuche sind auf der Innenseite mit einem Korrosionsschutzkleber versehen. Mit Heißluft oder Infrarotbestrahlung ist der Schrumpfschlauch aufzuschumpfen. Nach dem Schrumpfen muss die Wanddicke mindestens 1 mm betragen.

Heat shrink sleeves in combination with a PE-tube as a protection against mechanical stress are a permanent corrosion system for SAS tie rods. Heat shrink sleeves have a corrosion glue in the internal side. With heated air or infrared heat the heat shrink sleeve should be sheated. After shrinking the section thickness has to be minimum 1 mm.

Doppelter Korrosionsschutz (DCP) | Double corrosion protection (DCP)



SAS Zuganker werden in einem Ripprohr liegend mit einem Zementmörtel ausinjiziert. Um die mittige Lage des Zugankers im Ripprohr zu gewährleisten, werden Abstandshalter eingesetzt. Doppelt- Korrosionsgeschützte Zuganker können auch in aggressiven Medien eingesetzt werden.

SAS tie rods in a corrugated duct are injected with a cement mortar. To guarantee the centric position of the tie rod in the corrugated duct, internal spacers are used. Double corrosion protected tie rods can be installed in aggressive environment.

Zuganker, Gurtbolzen, Gurtung der Hauptwand, Gurtung der Ankerwand.

Tie Rod, waling bolts, waling of the main wall, waling of the anchor wall.

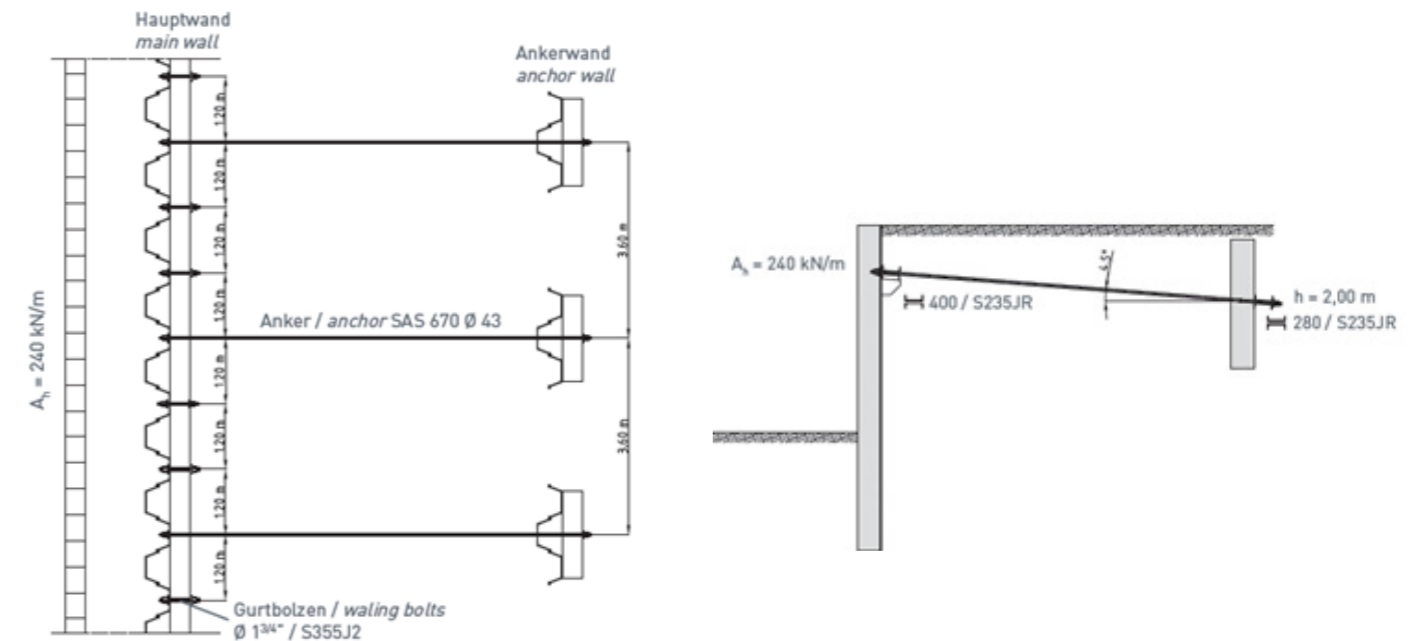

Berechnung und Bemessung der Spundwand	Calculation and design of sheet piling	Kapitel /chapter 8.2	
Tragfähigkeitsnachweis Spundwandbauwerke	Bearing stability verification sheet piling structures	Kapitel /chapter 8.2.6	
Rundstahlanker und Gurtbolzen	Tie rods and waling bolts	Kapitel /chapter 8.2.6.3	
Vorgaben	Specifications		
Ankerabstand	tie rod distance	[a]	3,60 m
Bemessungswert der einwirkenden Last	design value of the load	[A _d]	240 kN/m
Ankerneigung	anchor angle	[α]	4,5°
1. Zuganker	1. Tie rod		
Bemessungswert der Einwirkung	design value of the action	[Z _d]	[kN]
$Z_d = A_d \cdot x \cdot a / \cos \alpha = 240 \text{ kN/m} \cdot 3,60 \text{ m} / \cos 4,5^\circ = 867 \text{ kN}$			
gewählter SAS Gewindestab als Zuganker	chosen SAS thread bar as tie rod	[Ø]	SAS 670/800 Ø 43
Querschnittfläche	cross section area	[A]	1452 mm ²
Streckgrenze / Zugfestigkeit	yield stress / ultimate stress	[f _y / f _u]	670 N/mm ² / 800 N/mm ²
Bemessungswiderstand des SAS Zugankers	design resistance of the anchor	[R _d]	[kN]
$R_d = \min [F_{t, Rd}; F_{t, Rd}] = 884 \text{ kN}$			
Keine Reduzierung der Zugkraftbeanspruchbarkeit der SAS Zuganker durch Kerbfaktor!	No reduction of the tension strength of the SAS tie rod by a notch factor!		
Nachweis gegen Materialversagen	verification of material failure	[Z _d ≤ R _d]	
$Z_d \leq R_d = 867 \text{ kN} \leq 884 \text{ kN}$			
Nachweis gemäß EN 1993-5:2007+AC:2009 bzw. EAU 2012, Abschnitt 8.2.6.3 erfüllt	verification acc. to EN 1993-5:2007+AC:2009 resp. EAU 2012, chapter 8.2.6.3 fulfill	✓	
2. Gurtbolzen	2. Waling bolts		
gewählter Gurtbolzenabstand	chosen distance of waling bolts	[e]	1,20 m
Bemessungswiderstand des Gurtbolzens	design resistance of waling bolt	[F _{dG}]	240 kN/m
Bemessungswert Gurtbolzen	design value of waling bolts	[Z _{dG}]	[kN]
$Z_{dG} = Z_d \cdot e = 240 \text{ kN/m} \cdot 1,20 \text{ m} = 288 \text{ kN}$			
gewählter Gurtbolzen	chosen waling bolt		1 3/4"
gewählte Stahlgüte	chosen steel grade		S355J2+N
Querschnittfläche Kern	cross section core	[A _g]	1131 mm ²
Streckgrenze	yield stress	[f _{yG}]	355 N/mm ²
Bemessungswiderstand Gurtbolzen	design resistance waling bolt	[R _{dG}]	[kN]
$R_{dG} = A_g \cdot f_{yG} / \gamma_m = 1131 \text{ mm}^2 \cdot 355 \text{ N/mm}^2 / 1,10 = 365 \text{ kN}$			
Nachweis gegen Materialversagen	verification of material failure	[Z _{dG} ≤ R _{dG}]	
$Z_{dG} \leq R_{dG} = 288 \text{ kN} \leq 365 \text{ kN}$			
Nachweis gemäß EN 1993-5:2007+AC:2009 bzw. EAU 2012, Abschnitt 8.2.6.3 erfüllt	verification acc. to EN 1993-5:2007+AC:2009 resp. EAU 2012, chapter 8.2.6.3 fulfill	✓	

Verankerungen, Aussteifungen	Anchors, stiffeners	Kapitel /chapter 8.4
Tragsicherheitsnachweise Spundwandgurte (E30)	Verification of bearing capacity (R30)	Kapitel/chapter 8.4.2
Ansatz der Einwirkungen	Loads for the calculation	Kapitel/chapter 8.4.2.3
Berechnungsweise	Method of calculation	Kapitel/chapter 8.4.2.4

3. Gurtung der Hauptwand		3. Waling of the main wall	
max Moment im Gurt	max moment waling	$[M_{\max, dGurt}]$	[kNm]
Bemessungswert der einwirkenden Last	design value of the load	$[q]$	240 kN/m
Ankerabstand	tie rod distance	$[a]$	3,60 m
$M_{\max, dGurt} = q \cdot a^2/10 = 240 \text{ kN/m} \cdot 3,60 \text{ m}^2/10 = 311 \text{ kNm}$			
gewählte Gurtung	chosen waling] 400 U-profil
gewählte Stahlgüte	chosen steel grade		S235JR
Streckgrenze	yield stress	$[f_y]$	240 N/mm ²
Widerstandsmoment	moment of resistance	$[W_y]$	1020000 mm ³
zulässiges Moment	acceptable moment	$[M_{zul, dGurt}]$	[kNm]
$M_{zul, dGurt} = [f_y / \gamma] \cdot 2 \cdot W_y = 240 \text{ N/mm}^2 / 1,1 \cdot 2 \cdot 1020000 \text{ mm}^3 = 378 \text{ kNm}$			
[Beanspruchung aus Schiffsstoß; Teilsicherheitsbeiwert für Widerstandsgrößen um 15% vergrößert]	(stress from vessel impact; partial safety factors for resistance be increased by 15%)	$\gamma = 1,1$	
Nachweis gegen Materialversagen	verification of material failure	$\gamma_1 = 0,85$	
$M_{zul, dGurt} \leq M_{zul, dGurt} = 311 \text{ kNm} \leq 378 \text{ kNm}$			
Nachweis gemäß EAU 2012, Abschnitt 8.4.2 erfüllt	verification acc. to EAU 2012, chapter 8.4.2 fulfill		✓

4. Gurtung der Ankerwand		4. Waling of the anchor wall	
gewählte Ankerwand	chosen anchor wall		Dreifachbohlen/3-board
Ankerabstand	tie rod distance	$[a]$	3,60 m
Systemmaß	system dimension	$[c]$	1,20 m
Bemessungswert der einwirkenden Last	design value of the load	$[q]$	240 kN/m
max Moment im Gurt	max moment waling	$[M_{dw, Gurt}]$	[kNm]
$M_{dw, Gurt} = (q \cdot a \cdot c/3) / 2 = (240 \text{ kN/m} \cdot 3,60 \text{ m} \cdot 1,20 \text{ m} \cdot 1/3) / 2 = 173 \text{ KNm}$			
gewählte Gurtung	chosen waling		Dreifachbohlen/3-board
gewählte Stahlgüte	chosen steel grade		S235JR
Streckgrenze	yield stress	$[f_y]$	240 N/mm ²
Widerstandsmoment	moment of resistance	$[W_y]$	2.448000 mm ³
zulässiges Moment	acceptable moment	$[M_{zul, dw, Gurt}]$	[kNm]
$M_{zul, dw, Gurt} = [f_y / \gamma] \cdot 2 \cdot W_y / 1000000 = 240 \text{ N/mm}^2 / 1,1 \cdot 2 \cdot 448000 \text{ mm}^3 / 1000000 = 195 \text{ kNm}$			
Nachweis gegen Materialversagen	verification of material failure	$[M_{zul, dw, Gurt}] \leq M_{zul, dw, Gurt}$	
$M_{zul, dw, Gurt} \leq M_{zul, dw, Gurt} = 173 \text{ KNm} \leq 195 \text{ KNm}$			
Nachweis gemäß EAU 2012, Abschnitt 8.4.2 erfüllt	verification acc. to EAU 2012, chapter 8.4.2 fulfill		✓

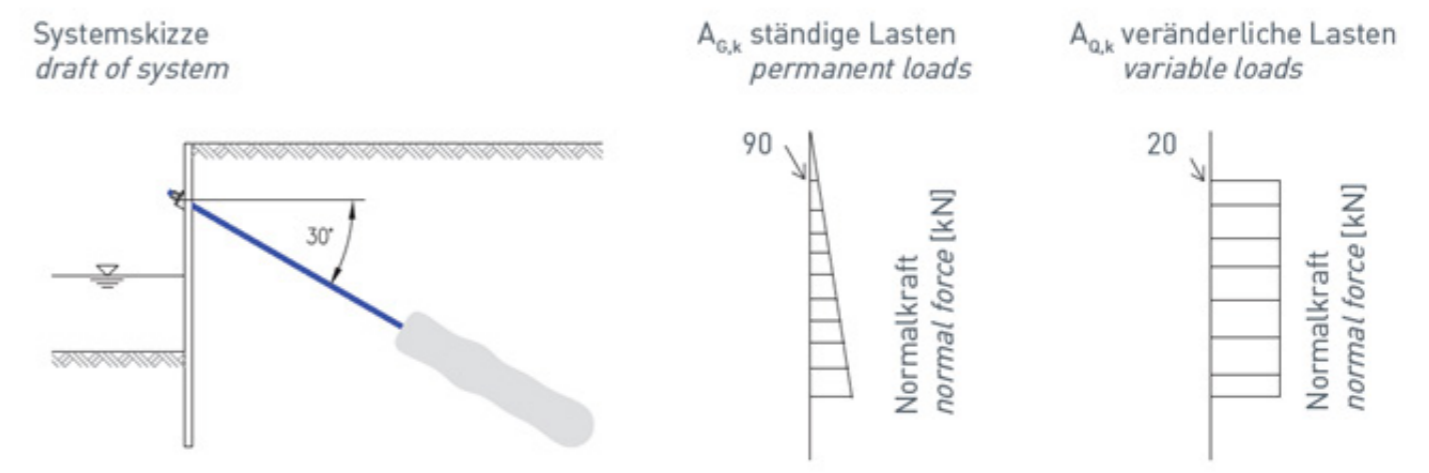

Berechnung und Bemessung des Verpressanker		Calculation of the ground anchor	
Einbauwinkel	installation angle	$[\alpha]$	30°
Bemessungswert der Einwirkung Last in Achsrichtung	design value of the load (axial direction)	$[A_v]$	[kN/m]
$A_v = A_{G,k} \cdot \gamma_{G_s} + A_{Q,k} \cdot \gamma_{Q_s} = (90 \text{ kN/m} \cdot 1,35 + 20,0 \text{ kN/m} \cdot 1,5) = 151,5 \text{ kN/m}$			
Ankerabstand	anchor distance	$[a]$	3,20 m
Bemessungswert der Einwirkung	design value of the anchor force	$[E_d]$	[kN]
$E_d = A_v \cdot a = 151,5 \text{ kN/m} \cdot 3,20 \text{ m} = 484,8 \text{ kN}$			
Stahlzugglied - Ø	steel tension rod - Ø		SAS 670/800 Ø35 mm
Querschnittsfläche	cross section area	$[A_s]$	962 mm ²
Teilsicherheitsbeiwert	partial safety factor	$[\gamma_M]$	1,15
DIN 1054:2005-01, Tab. 3 DIN 1054:2010-12, Tab. A2.3			
char. Spannung des Stahlzuggliedes	char. strength of the steel tension rod	$[f_{t,0,1,k}]$	[N/mm ²]
650 N/mm ² 0,1% permanent elongation			
Bemessungswert des Materialwiderstandes	design resistance of the material	$[R_{M,d}]$	[kN]
$R_{M,d} = A_s \cdot f_{t,0,1,k} / \gamma_M = 962 \text{ mm}^2 \cdot 650 \text{ N/mm}^2 / 1,15 = 543,7 \text{ kN}$			
Nachweis gegen Materialversagen	verification of material failure	$[E_d \leq R_{M,d}]$	
$E_d \leq R_{M,d} = 484,8 \text{ kN} \leq 543,7 \text{ kN}$			
Teilsicherheitsbeiwert für den Pfahlwiderstand	partial safety factor of the pile resistance	$[\gamma_p]$	1,40
Druck und Zug aufgrund von Erfahrungswerten	compression and tension due to experience		
Durchmesser des Verpresskörpers	diameter of the cement grout body	$[d]$	-250mm
char. Pfahlmantelreibung Sand und Kiessand	char. pile skin friction sand and gravel sand	$[q_{s1,k}]$	0,15 kN/m ²
Erfahrungswerte nach DIN 1054:2010-12 vgl. DIN 1054:2005-01, Anhang D	experience acc. to DIN 1054:2010-12 and DIN 1054: 2005-01, appendix D		
Bemessungswert der Pfahlmantelreibung	design resistance of the skin friction	$[T_d]$	[kN/m]
$T_d = q_{s1,k} \cdot \alpha \cdot d = 0,15 \text{ kN/m}^2 \cdot 1,40 \cdot 0,25 \text{ m} = 11,75 \text{ kN/m}$			
erforderliche Mindestverankerungslänge	required minimum length of anchorage	$[l_a]$	
$L_a = E_d \cdot \gamma_p / T_d = 484,8 \text{ kN} \cdot 1,40 / 11,75 \text{ kN/m} = 5,76 \text{ m}$			

SAS Gewindestäbe | SAS thread bar

Streckgrenze / Zugfestigkeit | yield stress / ultimate stress
Anwendungsbereiche | areas of application

Nenn- \varnothing | Strecklast | Bruchlast | Fläche | Gewicht | Dehnung
nom.- \varnothing | yield load | ultimate load | cross section area | weight | elongation
[mm] | [kN] | [kN] | [mm²] | [m/to] | [kg/m] | A_{gt} [%] | A₁₀ [%]

SAS 500 / 550 – grade 75

 Bewehrungstechnik | reinforcing systems

12	57	62	113	1123,6	0,89	6	10
14	77	85	154	826,4	1,21		
16	100	110	201	632,9	1,58		
20	160	175	314	404,9	2,47		
25	245	270	491	259,7	3,85		
28	310	340	616	207,0	4,83		
32	405	440	804	158,5	6,31		
36	510	560	1020	125,2	7,99		
40	630	690	1260	101,3	9,87		
43	726	799	1452	87,7	11,40		

 Geotechnik | geotechnical systems

50	980	1080	1960	64,9	15,40		
----	-----	------	------	------	-------	--	--

SAS 555 / 700 – grade 80

57,5	1441	1818	2597	49,1	20,38	5	---
------	------	------	------	------	-------	---	-----

SAS 555 / 700 – grade 80

63,5	1760	2215	3167	40,2	24,86	5	---
------	------	------	------	------	-------	---	-----

SAS 500 / 550 – grade 75

75	2209	2430	4418	28,8	34,68	5	---
----	------	------	------	------	-------	---	-----

Alternativ SAS 550 / 620 erhältlich | alternative SAS 550 / 620 available

SAS 450 / 700 – grade 60

 Bergbau | mining

16	93	145	207	617,3	1,62		[A ₅] 15
25	220	345	491	259,7	3,85		[A ₅] 20

SAS 650 / 800 – grade 90

 Bergbau | mining

22	247	304	380	335,6	2,98		[A ₅] 18
25	319	393	491	259,7	3,85		
28	400	493	616	207,0	4,83		
30	460	565	707	180,2	5,55		

SAS 670 / 800 – grade 97

 Geotechnik | geotechnical systems

18	170	204	254	500,0	2,00	5	10		
22	255	304	380	335,6	2,98				
25	329	393	491	259,7	3,85				
28	413	493	616	207,0	4,83				
30	474	565	707	180,2	5,55				
35	645	770	962	132,5	7,55				
43	973	1162	1452	87,7	11,40				
50	1315	1570	1963	64,9	15,40				
57,5	1740	2077	2597	49,1	20,38				---
63,5	2122	2534	3167	40,2	24,86				---

 Ankertechnik | tunneling & mining

 Hochfeste Bewehrung | high-strength reinforcement

SAS 950 / 1050 – grade 150

 Spanntechnik | post-tensioning systems

18	230	255	241	510,2	1,96	5	7
26,5	525	580	551	223,2	4,48		
32	760	845	804	153,1	6,53		
36	960	1070	1020	120,9	8,27		
40	1190	1320	1257	97,9	10,21		
47	1650	1820	1735	70,9	14,10		

 Geotechnik | geotechnical systems

SAS 835 / 1035 – grade 150

 Geotechnik | geotechnical systems

57	2155	2671	2581	47,7	20,95	4	---
65	2780	3447	3331	36,9	27,10		---
75	3690	4572	4418	27,9	35,90		---

SAS 900 / 1100 FA – grade 160 FA

 Schalungstechnik | formwork ties

15	159	195	177	694,4	1,44	3	7
20	283	345	314	390,6	2,56		
26,5	495	606	551	223,2	4,48	2	

SAS 900 / 1050 FC – grade 150 FC

 Schalungstechnik | formwork ties

15	159	186	177	694,4	1,44	3	7
20	283	330	314	390,6	2,56		

SAS 950 / 1050 E – grade 150

26,5	525	580	551	223,2	4,48	5	7
------	-----	-----	-----	-------	------	---	---

SAS 750 / 875 FS – kaltgerollt | cold rolled – grade 120 FS

 Schalungstechnik | formwork ties

12,5	90	120	132,5	961,5	1,04	2	5,5
15	142	165	189	675,7	1,48		
20	245	285	326	390,6	2,56		

Zubehör für alle Abmessungen und Anwendungen lieferbar | accessories for all dimensions and applications available